



Track-Dumper

RC 450



Snowblade



Track-Dumper RC 450

Technical Data

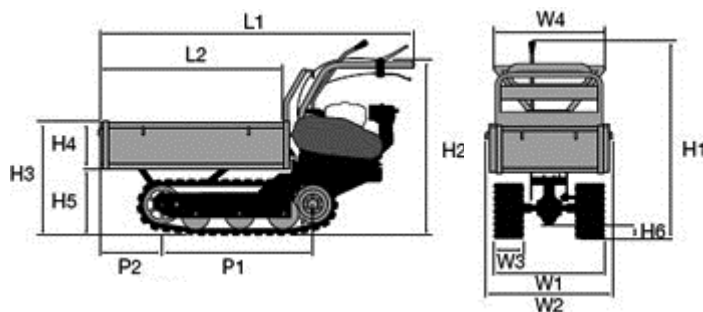

	mm	inches
L1	1670	65.75
L2	925 - 1060	36.42 - 41.73
H1	1020	40.16
H2	900	35.43
H3	590	23.23
H4	240	9.45
H5	339	13.35
H6	70	2.76
W1	620	24.41
W2	643	25.31
W3	-	-
W4	560-940	22.05 - 37.01
P1	785	30.91
P2	330	12.99

Engine	
Honda	GX 160
Type	1 cyl. / 4-stroke
Displacement	125 cm ³
Engine output	4.21 kW / 5.5 HP
Revolution speed	3600/rpm
Starter	Reversing starter
Air filter	Dry cartridge
Fuel filter	Seive

Drive	Toothed gearing
Brake	Automatic safety brake
Guidance	Steering brake
Load Carrying Beds	Bed length adjustable 1000-1180 mm / 39.4"- 46.5" Bed width adjustable 650-1100 mm / 25.6"- 43.3" Load height 240 mm / 9.4"
Characteristic	The loading area can be increased by pulling out the load carrying beds Load carrying beds can be pulled out completely



Yellow = Lever
Red = Throttle
Silver = Steering brakes



Unlock and tip mechanical by hand

Operation	
Weight	180 kg / 397 lbs.
Payload max.	450 kg / 992 lbs.
Tipping device	Mechanical
Climbing ability	Max. 26° (50%)
Working speed	1.88 km/h / 1.17mph 1st gear forward 4.13 km/h / 2.57mph 2nd gear forward 7.00 km/h / 4.35mph 3rd gear forward 1.86 km/h / 1.16mph reverse gear

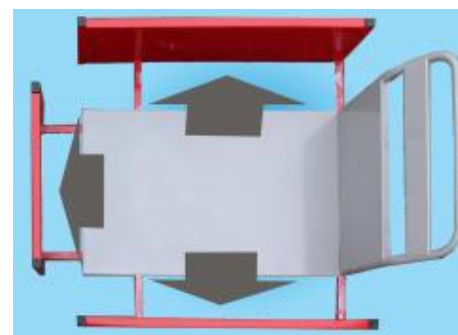

orders@gnhardscape.com
www.greatnorthhardscape.com
1.800.720.7627